

LOCK IDENTIFICATION SHEET

PART NUMBERS OR ANY MARKINGS

FACE PLATE

- FLAT
- U-RAIL
- WIDTH.....
- LENGTH.....

OPERATION

- KEY WIND UP
- LEVER OPERATED
- AUTO LOCK
- SPLIT FOLLOWER
- DOUBLE SPINDLE

CENTRE LOCK CASE

- LATCH & DEAD BOLT
- LATCH ONLY

NUMBER OF CAMS / BOLTS

- | | | | |
|---|--------------------------|----|--------------------------|
| 2 | <input type="checkbox"/> | 6 | <input type="checkbox"/> |
| 3 | <input type="checkbox"/> | 7 | <input type="checkbox"/> |
| 4 | <input type="checkbox"/> | 8 | <input type="checkbox"/> |
| 5 | <input type="checkbox"/> | 9 | <input type="checkbox"/> |
| | | 10 | <input type="checkbox"/> |

TYPE OF CAM / BOLT

- RO = ROLLER CAM
- MU = MUSHROOM CAM
- SH = SHOOTBOLT
- HB = HOOK BOLT
- RB = ROUND BOLT
- DB = DEAD BOLT

ANY COMBINATION PLEASE STATE.....

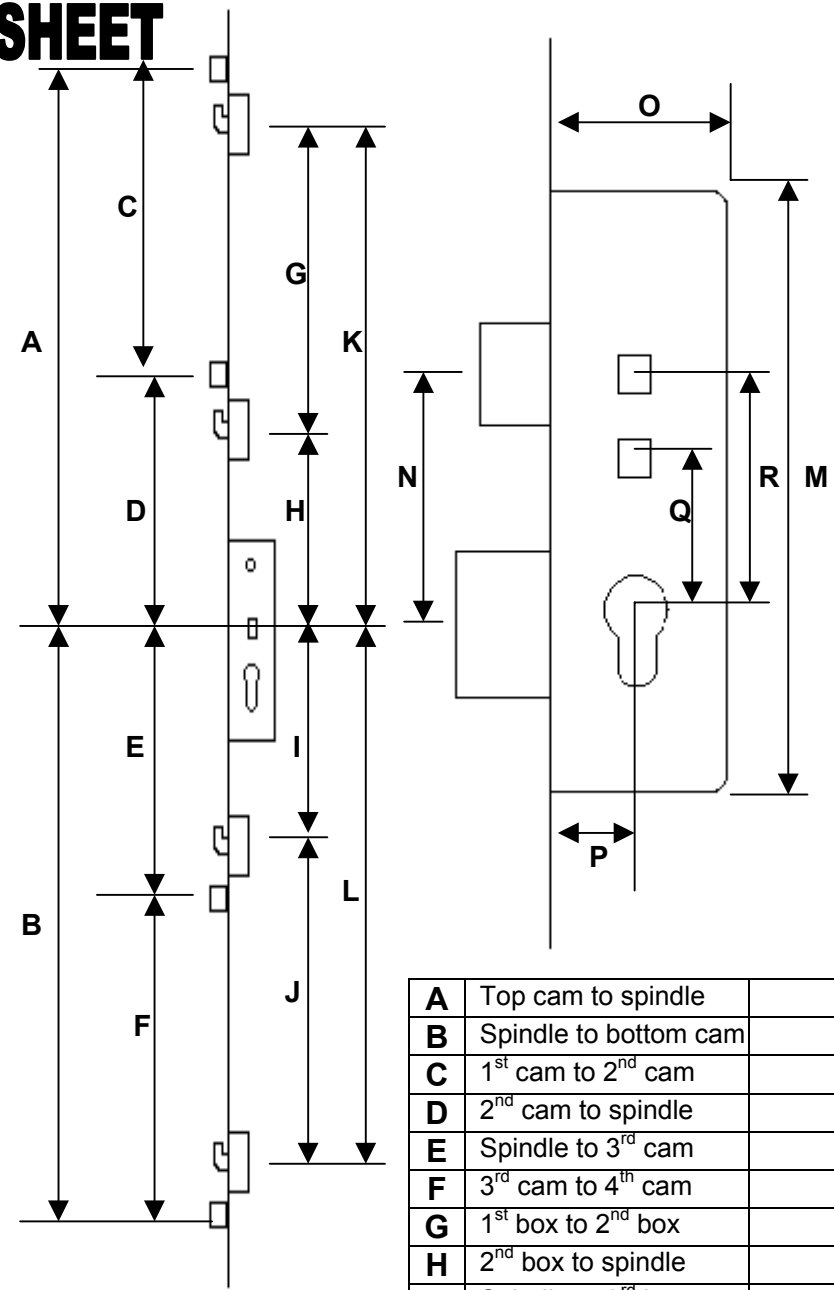

A	Top cam to spindle	
B	Spindle to bottom cam	
C	1 st cam to 2 nd cam	
D	2 nd cam to spindle	
E	Spindle to 3 rd cam	
F	3 rd cam to 4 th cam	
G	1 st box to 2 nd box	
H	2 nd box to spindle	
I	Spindle to 3 rd box	
J	3 rd box to 4 th box	
K	Top box to spindle	
L	Spindle to bottom box	
M	Case length	
N	Latch to dead bolt	
O	Case depth	
P	Back set	
Q	1 st centre (PZ)	
R	2 nd centre (PZ)	
S	Other	
T	Other	

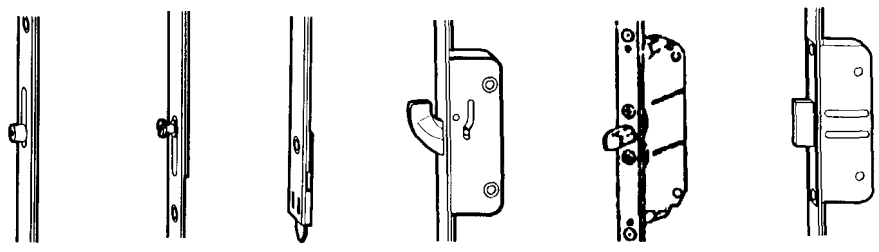

RO MU SH HB RB DB